

World Sailing International A Class Catamaran-Measurers' Guide

All A Division Catamarans shall have a valid measurement form for sail, mast & hull which are available on the IACA website. These forms are largely self-explanatory and the following notes should assist in their understanding. The Class has recently approved a total class rule rewrite to bring us in line with World Sailing guidelines. The new class rules are now based around the standard template used for all international classes and broken into various sections A, B & C which are closed class rules and sections D, E, F and G which are open class rules. We have also now adopted the use of the ERS (Equipment Rules of Sailing), which is a valuable source of measurement information and interpretations. This rewrite takes effect from 08/06/2018 and should be read in conjunction with this guide and the ERS

Hull Measurement

This form comprises all the measurements related to the hull and its appendages: length, width, maximum appendage width, minimum appendage width from boat centerline and maximum distance of rudder assembly from hull stern.

All boats constructed after 1/1/2010 must have an ISAF/ World Sailing plaque affixed to one of the transoms before measurement certificate can be issued.

Length

The overall length of the craft is 5.490m, which is the hull length. It does not include rudder hangings/gudgeons and is basically the distance between perpendiculars to the extremities of the hull in normal trim (boat approximately parallel with waterline) and any other fittings attached to boat, other fittings may include foot loops, inspection ports and external transom reinforcement.

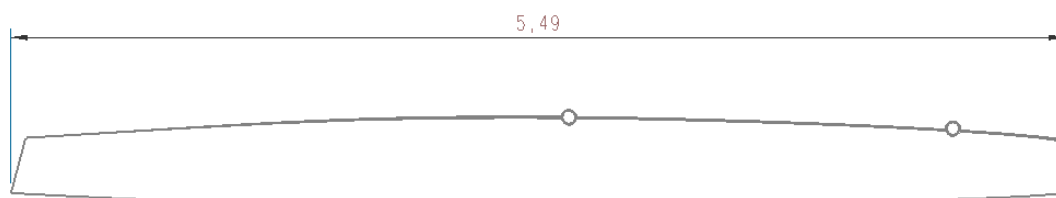

If the transverse width of a rudder assembly measured parallel to boat centerline excluding rudder hangings/gudgeons in a fully down position within 153mm of the closest lowest vertical hull point is more than 76mm, the length measurement needs to go to the aftermost point of the rudder assembly.

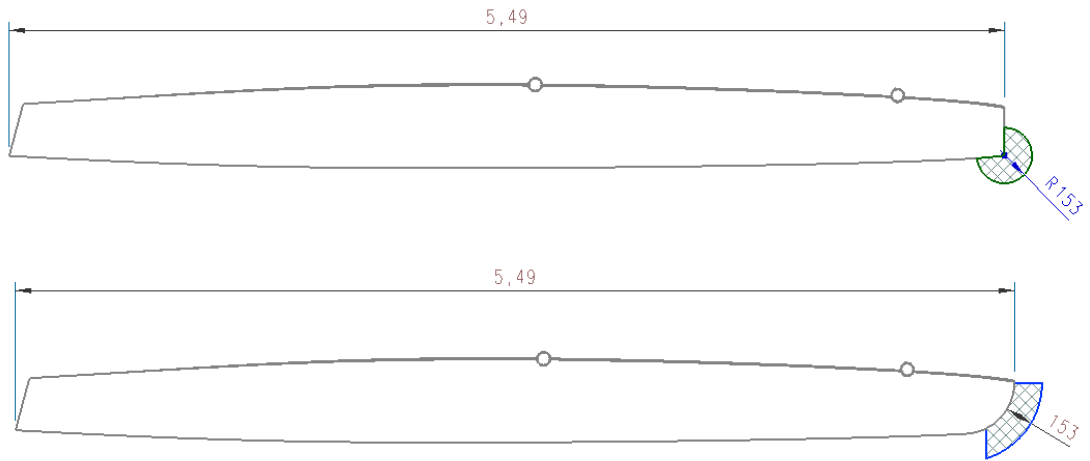

The lowest vertical hull point is the closest lowest points on the hull at all transverse sections. This means that on any point of a hull if a cross section cut was taken the lowest point of this cut would define this point. We are looking for the closest point to the rudder assembly. With “standard” type hulls at present with flat stern this point would be at the lowest point of the intersection of stern and hull bottom. Should you encounter a boat with a canoe type stern this point could effectively move around hull stern.

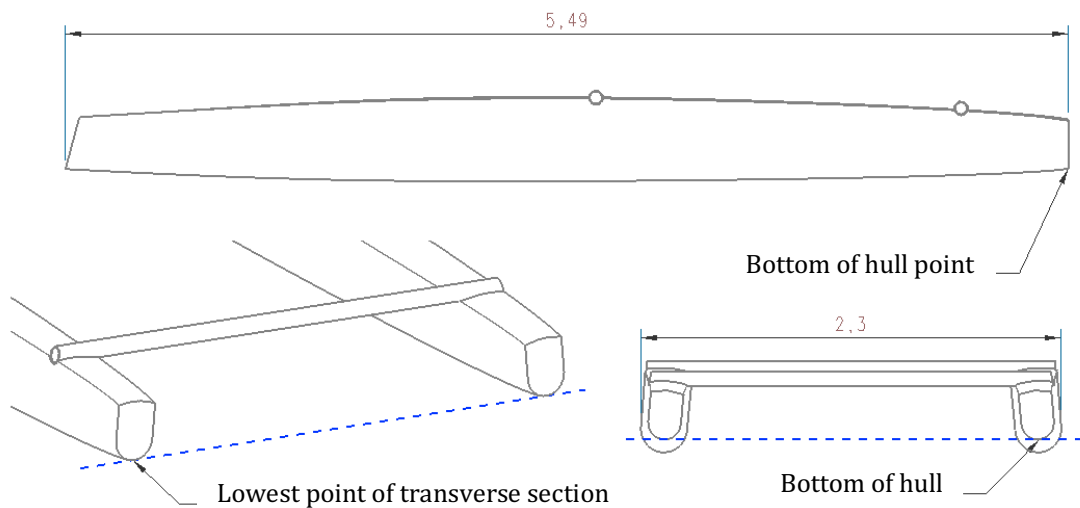

Width

The overall width of the craft is 2.300m and this measurement is taken at the widest point of the hull. This may be at some point down the sides of the hulls, especially if hulls are angled or at the very top if hull rails or ledges are attached for trapezing, foot loops attached to hulls are also included in width.

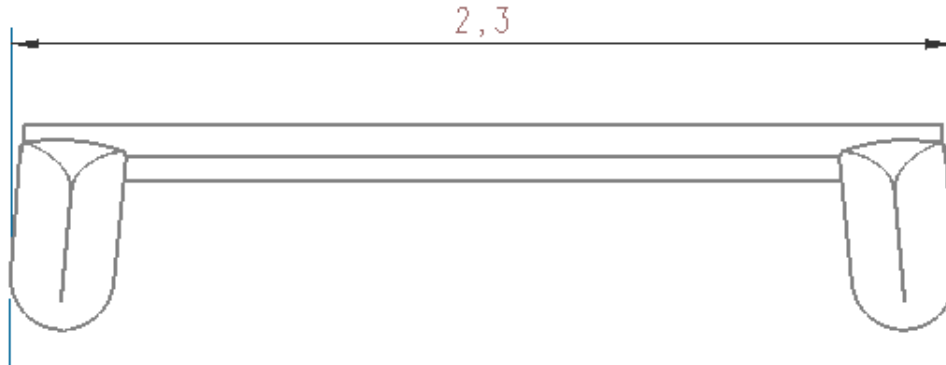

Appendages

All hull appendages flush with the bottom of the hull until fully down must fit within this maximum width of 2.300m and a minimum distance of .750m from boat centerline measured in a full range of motion (i.e. extension/retraction, cant and rake).

Centreboards must be able to be inserted from the top of hull and be easily removable on land and water or be capable of being fully retractable into the hull (We have not seen this aspect in current boats but they would be similar to centreboards used on say Tornado, 470 etc.)

All measurements for hull appendages are to be taken in a static position. Should appendage be moveable in case or box, appendage to be placed so that least desirable measurement is taken. Rudder measurements are taken with rudders parallel to boat centerline.

If a cassette type rudder fails to comply with the maximum width of 2.300m, the minimum 0.750m distance from centerline or the 0.300m from the aft most point of the hull at any point when raised from the fully down to fully up position, a **non adjustable** method of locking the rudder in place or limiting the retraction so all rudder rules are met must be in place. The method of locking or limiting must be able to be replicated at each and every measurement or equipment inspection.

The locking or limiting mechanism must be engaged at all times while racing.

Centreboards

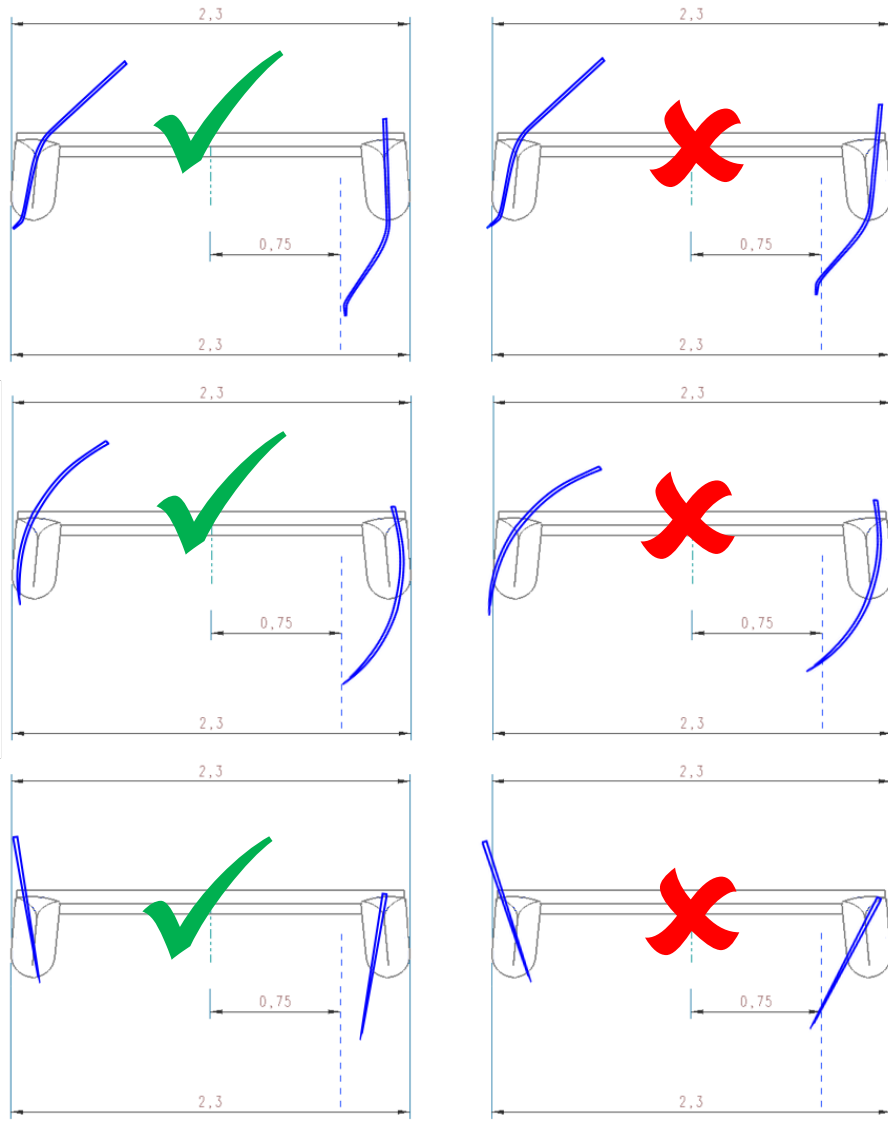

Rudders

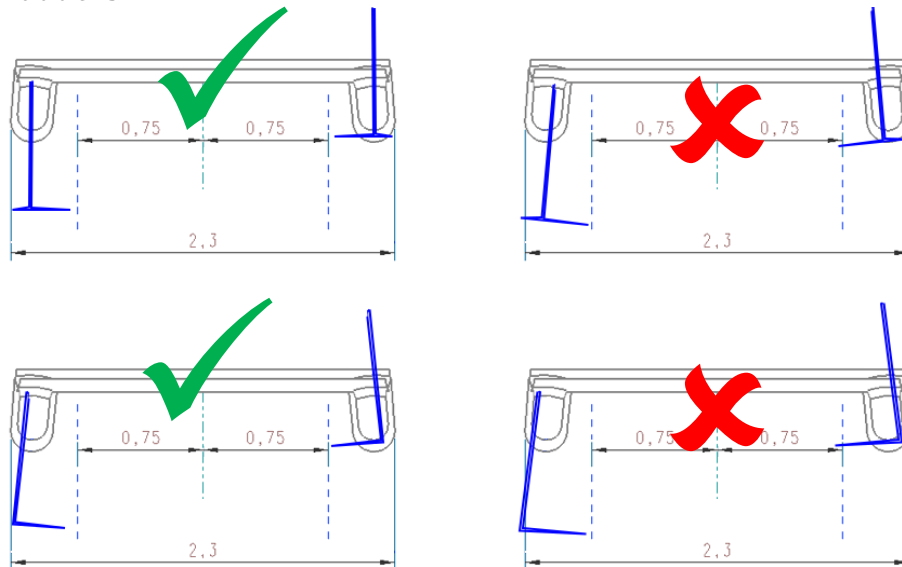

Rudder Assembly

The rudder assembly, which may consist of the rudder blades, stocks/cases and rudder hangings/gudgeons must fit within 0.300m of the aftermost point of the hull.

This measurement is taken in all positions below the closest highest vertical hull point through a full range of motion (i.e. extension/retraction, cant and rake).

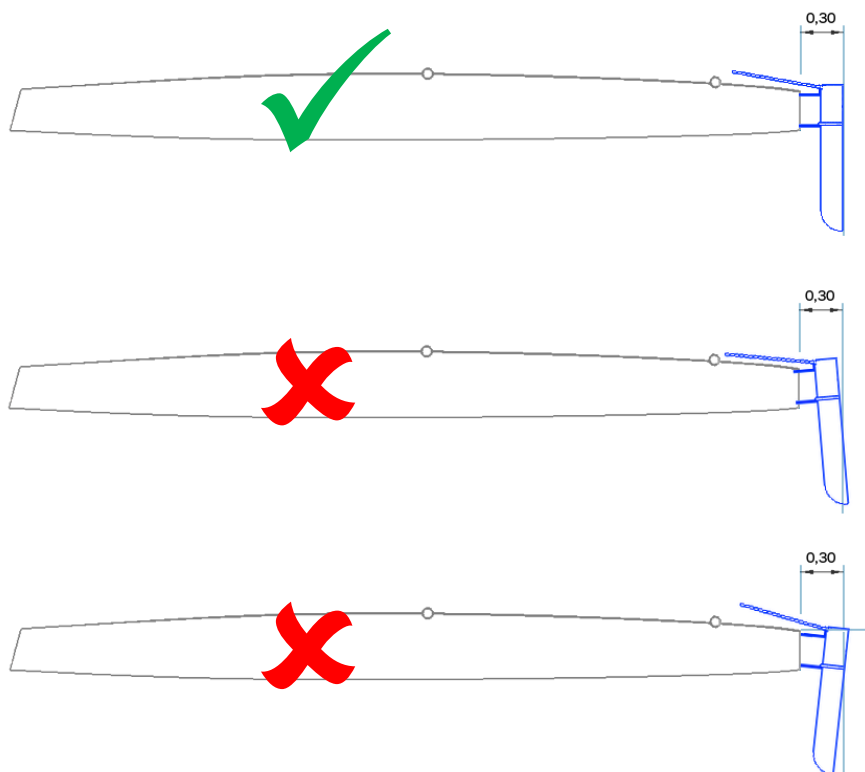

The ERS has no definition of a gudgeon so anything that holds the rudder box to the back of the boat fits our rules. To take advantage of this 0.300m measurement (Rule E2.1) many new designs of rudder gudgeons/hangings have appeared. The way to assess each gudgeon/hanging is to ask the following question: Does the design of the rudder gudgeon/hanging do anything else other than hold the rudder box and in need allow rudder rake to be adjusted and fit within 0.300m from the stern? If the answer is no and the following exceptions are not evident then deemed ok.

The rudder assembly cannot form an extension of the hull length, so there must be a clear separation from the sides, top & bottom of the hull to the gudgeon assembly. The new Exploder assembly clearly shows this. Rule E.5(c)



The rudder assembly cannot be part of the hull construction, The DNA F1 gives the impression this is the case however this is only due to their excellent workmanship as the box type structures extending the rudder box out are additions to the actual hull, not included in the hull mold and glued and faired to the back of the hull, the fairing into the back of the hull has not extended the hull length. Rule E.5(c)



Attachments to the hull whose only purpose is to restrict the sideways movement of the gudgeon are allowed, however in this case the outside block is flush with the side of the hull and would not be allowed under Rule E.5(c).



Any attachment to the actual hull whose only use is to anchor control systems or to strengthen the stern in a particular area is not considered part of the rudder assembly and is to be include in the overall hull length. Rule D.4.1 (a).



Sail Measurement Form

When undertaking sail measurement the following points should be noted.

Sail to be measured on a flat surface and laid out in terms of the IYRU Measurement & Calculation of Sail Area Instructions, that is:

(A copy of these instructions from the ISAF International Measurers manual is on the IACA website)

“ With battens set in their pockets the sail shall be pegged out on a flat surface with just sufficient tension to remove waves or wrinkles from the edge rounds and to spread the sail as far as possible, substantially flat. Once the sail has been pegged out in this way all the required measurements shall be taken and no alterations to the tensions shall be made.”

Luff length A is the maximum distance from the head to the tack of the sail. It is taken on the inside of the boltrope, which is not included in any measurement.

Base length P is a measurement from the clew to a point at 90 degrees to A.

Measurement M, F, K, D and H are all made at 90 degrees to their respective lines. All are to be the maximum distance that can be taken provided offsets are constant curves. Note this may mean that some measurements are zero or in the case of a hollow leech or foot a negative figure and this must be shown as such on measurement form. Negative areas can be deducted from overall sail area.

The sail measurement form should be used as a guide only and to date has adequately covered standard type sails as in Fig1.

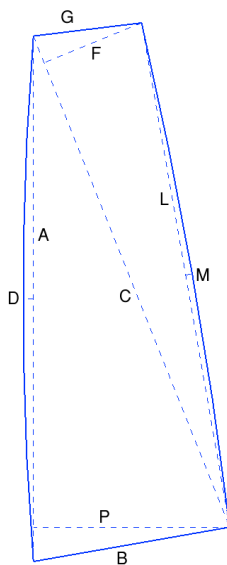

Fig 1. F measurement may be to top of sail thus eliminating, J, H & K measurements.

Fig 2

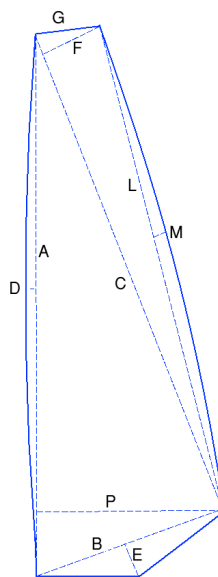
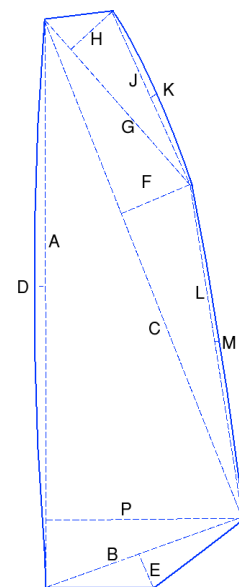

Fig 3



The advent of decksweeper type sails has presented a new challenge and as a measurer we must adjust accordingly. Remember the principals are the same with the basic goal to measure the total area of the sail. Measurement is made up of the total areas of triangles and offsets. It is your responsibility to use a combination of these to give the most accurate measurement. The basics of head, tack and clew still remain and in the decksweeper diagram (Fig2) the lower part of the sail now can be looked at in a similar fashion to foot round which we would normally calculate as $\frac{2}{3}(B \times E)$ due to the constant curvature of the foot. In this case, however, as all sides are straight we can adjust to $\frac{1}{2}(B \times E)$ as we are measuring a triangle. This change simply needs to be noted on the measurement form so an Equipment Inspector can see what has happened. You have the option of further breaking the sail into further triangles and off sets if considered necessary to give further roach area measurements. We are now seeing sails that do not have a constant leach curve and in this case it may be necessary to use all roach area measurements as noted on measurement form. (Fig3)

End Plates/ Sail Flaps

Decksweeper type sails attempt to obtain an "end plate" effect by the sail touching the trampoline. As long as the sail is not attached to the trampoline this is legal. Should this not be the case then the measurement guidelines state that only elements of the sail plan that are vertical are measured. Elements of the sail plan which are horizontal or nearly so when the yacht is not heeled are not measured provided the total area of the end plate surface does not exceed 10% of the total sail area (1.394sqm). Note this measurement is the area of one side of the end plate only. Individual circumstance will dictate how big this area may be. For a boat that has a trampoline fully sealed to the hulls it could be $\frac{1}{2}$ the total area of the trampoline and the horizontal surfaces of all hulls. Your calculation needs to be fully documented and noted on measurement form.

We are also seeing the advent of adjustable flaps added to decksweeper sails to adjust the foot of the sail to the trampoline profile. These flaps or similar can be adjusted on the sail with Velcro or similar type fastening. This flap needs to be measured in its maximum position and added to the total sail area and mast area, again note this on measurement form.

Class Emblem, Country Code & Sail Numbers

The class emblem, national letter and distinguishing numbers shall be placed as prescribed in the Racing Rules of Sailing (RRS77 & RRS Appendix G) Basically the national letters and sail numbers must be clearly legible, the same colour and minimum 60 mm from edge of sail and each other. No numbers shall be lower than 60% of luff length from head of sail.

Following measurement, Measurer is to write the following on bottom starboard side of sail.

Note: this is a mandatory requirement.

SA=???sqm
Luff =???m
Base=???m
Measurer's Signature
Date

Mast & Boom Measurement Form

The purpose of this measurement is to find half the total area of the mast and any mast base fitting and fairing devices attached. On a straight section (i.e. not tapered) it is simply the length of mast and base x half the mast girth. The Measurement and Calculation of Sail Area instructions define girth as follows:

“ The girth measurement shall be taken as the distance from the centerline round the surface of the spar to the same point on the centerline. The resultant dimension shall be divided by two to give the half girth measurement”.

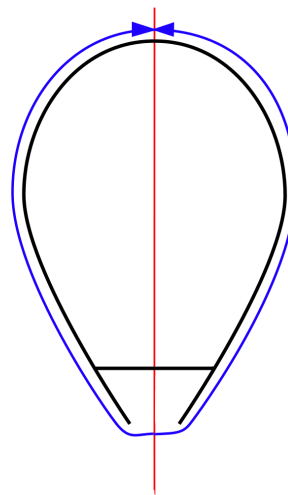

Note: The total girth measurement includes the sail track opening.

Should mast be tapered extra measurement U1 & T need to be taken and the formula on the measurement certificate utilized.

Double tapered masts also need the T2 and U2 measurement to be taken. The most common case of a double tapered mast is the Fiberfoam DNA mast, which doesn't have a straight section in the middle. This means that $L=T1+T2$, and therefore the formula can be simplified a little.

Following measurement, Measurer is to write the following in a contrasting colour on the starboard side of mast near the base.

Note: This is a mandatory requirement.

MA = ???sqm
SN = ?(mast serial no. If not legible on mast)
Measurer's Signature
Date

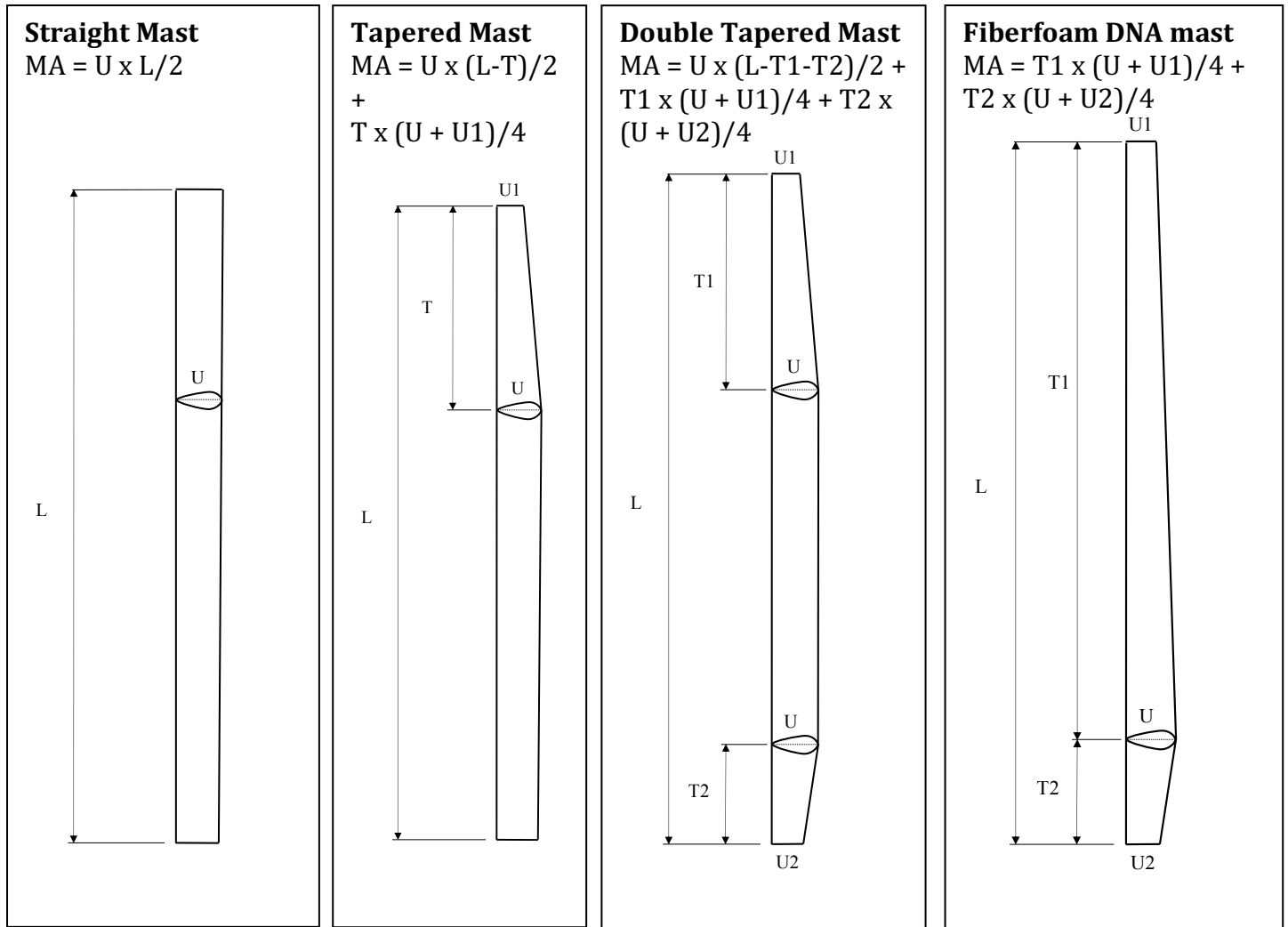

Boom measurement is only utilized if the profile height of the boom is more than 1.5 of the width. Boom fittings and anti-fouling such as boom sleeves are allowed as long as their primary purpose is to maintain the safe working of running systems.

General

Boat weight is not included on any of these forms as this is the owner's responsibility to apply and carry any correctors if necessary. The weight of the boat consists of all equipment used to take part in a race and may include a compass. Spare battens allowed under our Championship Rules, consumables, portable equipment and personal equipment are not to be included in a boat's weight.

(Note spare battens used in a race shall not weigh less than those included in the measurement weight.)

The boat must be weighed in dry condition and any weights attached to bring the boat to a minimum weight of 75.000 kilograms must be securely fastened to the boat.